

## HIGH CURRENT BUSHING ASSEMBLIES 5 kV CLASS, 75 kV B.I.L., 5.00" MIN CREEP SIDEWALL OR COVER MOUNTED

The electrical ratings given are based on use in a liquid filled transformer with the lower end of the bushing under oil level. Bushing is produced of top quality electrical grade wet process porcelain. Gray glaze is standard unless otherwise specified. Nitrile (Buna-N) gasket is standard. For ordering assemblies with the cork and rubber composition gaskets add the suffix "C" to the part number.

All spade castings consist of 95% min. conductivity copper and are tin-plated. Bushings can be furnished upon request at a discounted price, with spades made of lower conductivity copper alloys such as brass, bronze, etc.

Bushings are designed for mounting in 3.38" diameter hole.

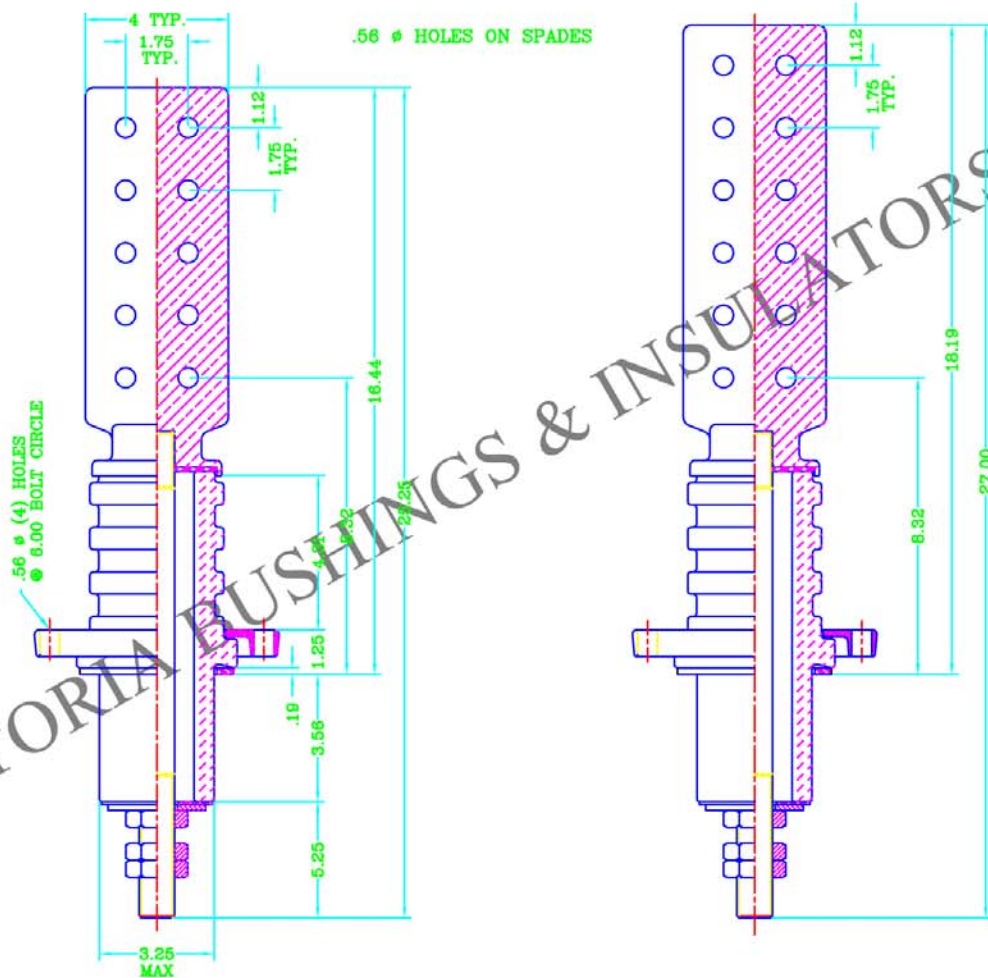

PART NO.	CONNECTOR TYPE	CONNECTOR THICKNESS	STUD SIZE AND THREAD	CURRENT RATING
320263	10 HOLE SPADE	0.50	1.00-14 UNS-2A	800 A
320264	10 HOLE SPADE	0.50	1.13-12 UNF-2A	1000 A
320265	10 HOLE SPADE	0.50	1.25-12 UNF-2A	1200 A
320266	10 HOLE SPADE	0.50	1.50-12 UNF-2A	1600 A
320267	10 HOLE SPADE	0.75	1.75-12 UN-2A	2400 A
320268	10 HOLE SPADE	0.75	2.00-12 UN-2A	3000 A
320269	10 HOLE SPADE	0.75	2.13-12 UN-2A	3350 A
320273	12 HOLE SPADE	0.50	1.00-14 UNS-2A	800 A
320274	12 HOLE SPADE	0.50	1.13-12 UNF-2A	1000 A
320275	12 HOLE SPADE	0.50	1.25-12 UNF-2A	1200 A
320276	12 HOLE SPADE	0.50	1.50-12 UNF-2A	1600 A
320277	12 HOLE SPADE	0.75	1.75-12 UN-2A	2600 A
320278	12 HOLE SPADE	0.75	2.00-12 UN-2A	3200 A
320279	12 HOLE SPADE	0.75	2.13-12 UN-2A	3600 A