

## STANDARD LOW VOLTAGE BUSHING ASSEMBLIES 1.2 KV CLASS, 30 KV BIL EXTERNALLY CLAMPED TYPE

The electrical ratings given are based on use in a liquid filled transformer with the lower end of the bushing under oil level. Bushing is produced of top quality electrical grade wet process porcelain. Gray glaze is standard unless otherwise specified. Nitrile(Buna-N) gasket is standard. For ordering assemblies with the cork and rubber composition gaskets add the suffix "C" to the part number.

All spade castings consist of 95% min. conductivity copper and are tin plated. Bushings can be furnished upon request at a discounted price, with spades made of lower conductivity copper alloys such as brass, bronze etc.

Bushings are designed for mounting in 2.69" diameter hole.

The bushing is keyed to the 2 piece clamp and the connector is keyed to the porcelain insulator to prevent rotation.

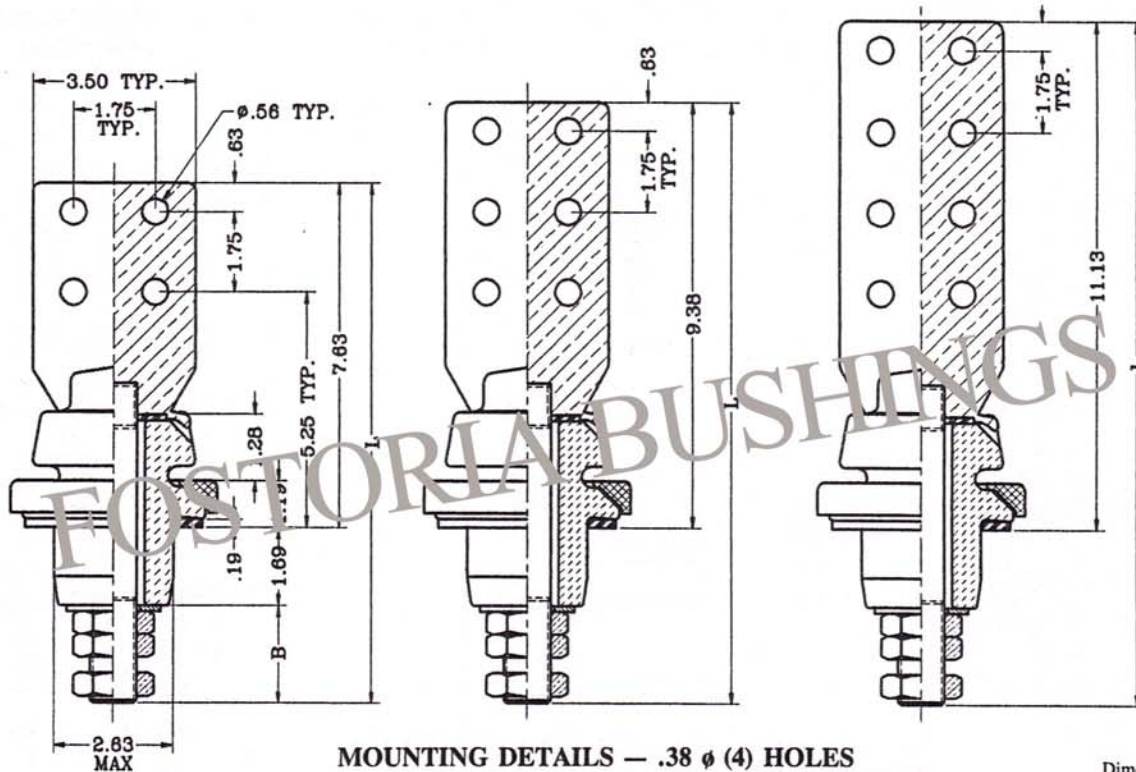

**MOUNTING DETAILS — .38  $\phi$  (4) HOLES  
@ 4.63 BOLT CIRCLE**

Dimension Changes  
Rev. 1, May 1996

PART NO.	CONNECTOR TYPE	CONNECTOR THICKNESS	STUD SIZE AND THREAD	CURRENT RATING	DIMENSION IN INCHES	
					L	B
300511	H SPADE	0.38	0.625-18 UNF-2A	417 A	11.19	1.87
300512	H SPADE	0.38	0.750-16 UNF-2A	600 A	11.19	1.87
300513	H SPADE	0.38	1.000-14 UNS-2A	800 A	11.44	2.12
300515	H SPADE	0.50	1.250-12 UNF-2A	1200 A	11.82	2.50
300531	6 HOLE SPADE	0.38	0.625-18 UNF-2A	417 A	12.94	1.87
300532	6 HOLE SPADE	0.38	0.750-16 UNF-2A	600 A	12.94	1.87
300533	6 HOLE SPADE	0.38	1.000-14 UNS-2A	800 A	13.19	2.12
300535	6 HOLE SPADE	0.50	1.250-12 UNF-2A	1200 A	13.57	2.50
300551	8 HOLE SPADE	0.38	0.625-18 UNF-2A	417 A	14.69	1.87
300552	8 HOLE SPADE	0.38	0.750-16 UNF-2A	600 A	14.69	1.87
300553	8 HOLE SPADE	0.38	1.000-14 UNS-2A	800 A	14.94	2.12
300555	8 HOLE SPADE	0.50	1.250-12 UNF-2A	1200 A	15.32	2.50